

Technical Specification

Channelisation format:	TDMA (Time Division Multiple Access)
Range:	Line of sight operating ranges with integrated power output options of up to 10W
Frequency bands:	VHF 136 - 174MHz UHF 440 - 512MHz
Number of channels:	The transceivers are configured to use any 10 channels in the band with the system configuration software
Transmitter power output:	10mW, 500mW or 2W software selectable, optional 10W integral PA
CCIR emission designator:	25KOF1D/12K5F1D
Error correction:	Byte level Hamming (12,8) code, correcting 1 bit per byte, interleaved into blocks of 20 bytes
Antennae	
Standard:	Integrated GPS and VHF/UHF with single cable, max power 10W
GPS:	L1(1.575GHz), Gain 40dB, 5V DC, Azimuth 360 deg, Zenith 0 deg to 90 deg
VHF:	136MHz to 174MHz, -0.3dBd with optional radials, -3dBd surface mounted
UHF:	440 - 512 MHz
Optional:	Separate GPS and VHF/UHF antennae
GPS receiver	
Standard:	8 channel receiver
High accuracy:	12 channel receiver
Precision:	Real Time Kinematic
Power supply:	9V to 36V DC. Load dump protection to 250V
Power consumption	
Maximum:	Transmit (2W P.A. 100% duty cycle) 12W Transmit (10W P.A. 100% duty cycle) 40W Receive 4W
Typical:	Transmit (2W P.A. 1 report/sec) 5W Transmit (10W P.A. 1 report/sec) 7W
Temperature:	Operating -30 °C to + 60 °C Storage -45 °C to + 70 °C
Waterproofing:	Tracs-TDMA and antenna IP 67 compliant. Dust proof with short term immersion to 1 metre GeoPod IP 68 compliant. Dust proof with immersion to 10 metres
Dimensions and weight:	TDMA: L 246mm W 140mm H 95mm, 3kg GeoPod: L 603mm Diam 90mm, 4.5kg Excluding connectors with cables
Type Approval:	TDMA: Meets ETS 300-113, CE approved GeoPod: Meets UK MPT 1329 band 458.5 to 458.8 MHz, CE approved

THALES TRACS



TRACS-TDMA

Tracs-TDMA is an intelligent radio data network which integrates advanced UHF and VHF communications with GPS technology. Offering outstanding configuration flexibility, and the advantages of unique automatic repeater capabilities, Tracs-TDMA is ideal for complex tracking and communications tasks including:

- Vessel tracking
- Vehicle tracking
- Personnel tracking
- Fleet management
- Port vessel monitoring
- Geophysical field operations management

Key user benefits of Tracs-TDMA

- Real time mobile tracking with either Real Time Kinematic or standard DGPS accuracy
- System provides continuous location of all mobile units 'at a glance'
- Auto adaptive repeater mode extends operating range in areas where direct communications is obstructed
- Advanced technology permits reliable signal transmission in difficult conditions without operator intervention
- Use of messaging facility for the broadcast of navigational instructions such as waypoints and guard zones reduces voice radio traffic and speeds communications
- Advanced error correction as standard
- Emergency alarm for vehicle/operator security

THALES

Thales Tracs Limited

Compass House · Davis Road · Chessington · Surrey · KT9 1TB · United Kingdom
Tel: +44 (0)870 601 0000 · Fax: +44 (0)181 391 1672 · E-mail: contact@thales-tracs.com

Thales reserves the right to vary detail on the description and specification contained in this leaflet. Publication No: 0268/0801/1388D. ©2001



www.thales-tracs.com

THALES

Tracs-TDMA advanced features

Tracs-TDMA is an intelligent data network system which operates at UHF and VHF frequencies permitting continuous real-time messaging from a wide variety of applications. Operating on a Time Division Multiple Access principle the system is extremely flexible in configuration, giving the mobile data system integrator complete control over messaging rates and content.

Each mobile unit within the Tracs-TDMA system is allocated a unique identity code and transmits its position or other data in a time slot assigned to it. Transmission timing is synchronised by GPS and revised by the control centre as required. All transmitted data carries a tag identifying its origin and destination and this enables other mobile units in the operating area to monitor the data network and automatically forward messages if direct transmission is blocked. This unique technology enhances communication reliability and can significantly extend the operational range of the Tracs system beyond the normal line of sight restrictions.

Tracs-TDMA is ideal for real-time tracking applications allowing the reporting of GPS position of mobile units back to a control centre display system. At the same time, Differential GPS corrections can be broadcast through the network for precise positioning applications. The system operates on a single UHF or VHF frequency and can handle up to 250 mobile reports per radio channel although this capacity can be expanded by the use of additional channels in a cellular configuration.

Technical capabilities

Data communication between units

As well as position reporting to a control centre and the distribution of RTCM data, messages can be routed from one mobile to another. Selective or group messaging is possible from the control centre as is the facility for units to be configured dynamically. Voice radio traffic can be reduced and communications in crowded frequencies made faster as a result.

Auto adaptive repeater mode

Any Tracs-TDMA unit in a system can operate intelligently as a repeater. Each mobile unit monitors the communications status of all other units in its local area, and should the path between 2 units be obscured, the unit will automatically deduce which path is blocked and undertake to pass on the message during the next time slot allocated to the originator of the message. In this way messages can be re-broadcast to circumvent radio line of sight limitations or to relay messages made from beyond the network's normal radio range.

System capacity

Transmission of data within a 'cell' is via a single radio channel. Each unit's access to the network is configured during initial set-up. A typical mobile reporting interval would be 10 seconds, depending on priority, which would allow spare capacity to be allocated to fast mobiles and any dedicated repeaters. The frequency of position reports from mobile units can be changed by the control centre enabling it to focus on units involved in critical activities.

Accessories and options

GPS modules and configurations

Tracs-TDMA is available with either standard (2-4 metre) or precision (better than 1 metre) accuracy.

Display systems

A range of mapping and display systems is available depending on the application and on the functionality required. Alternatively, assistance can be provided for the integration of Tracs-TDMA data into existing display systems.

Emergency alarm facility

Mobile units can be fitted with an alarm button which causes the system to transmit an emergency position and status report with minimum delay. Emergency transmissions can be detected and acknowledged by adjacent mobiles as well as the control centre.

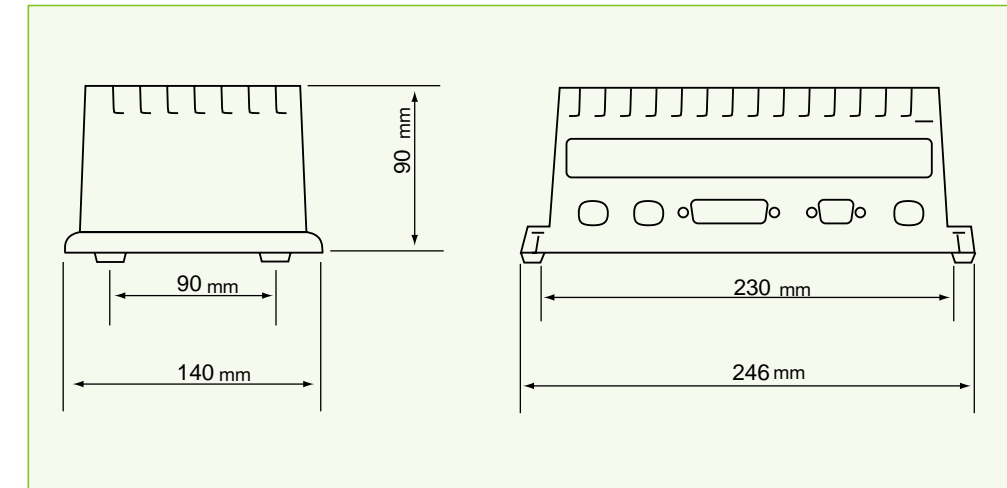

System software and user interfaces

Several packages are available for planning, configuring and operating the network depending on the client's requirements.

Network planning software

This is used to assign transmission slots to mobiles to meet their perceived requirements for data capacity. The configuration file is then passed to the configuration software.

Configuration software

Enables the units to be set up as required in the network planning software via a serial cable from a PC. Units retain the configuration in memory until reprogrammed.

Tracs communications controller (Tracs-CC)

Data can either be extracted directly from a Tracs-TDMA unit by the application software or Tracs-CC software can be used to manage the Tracs-TDMA data. This software is of particular benefit when larger systems are being used which include several base stations.

Control centre software

PC software to manage a database of the position reports and a graphical display of mobile locations is available. In addition, the software can provide message scheduling, co-ordinate conversion, system monitoring and network control functions for inclusion in either simple, single base station systems or multiple base/frequency systems.

GeoPod - pod unit

The Tracs-GeoPod unit is a variant of the system designed for extremely hostile environments or conditions. The unit is designed for the rough handling that can be experienced in high shock environments and is waterproof to 10 metres.